

Current Transformers

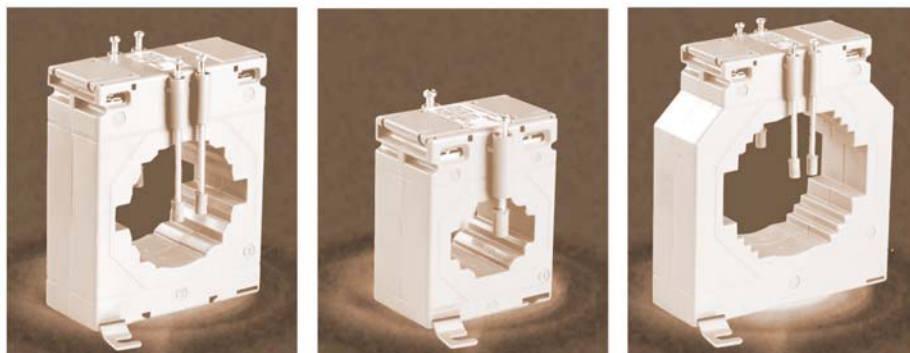
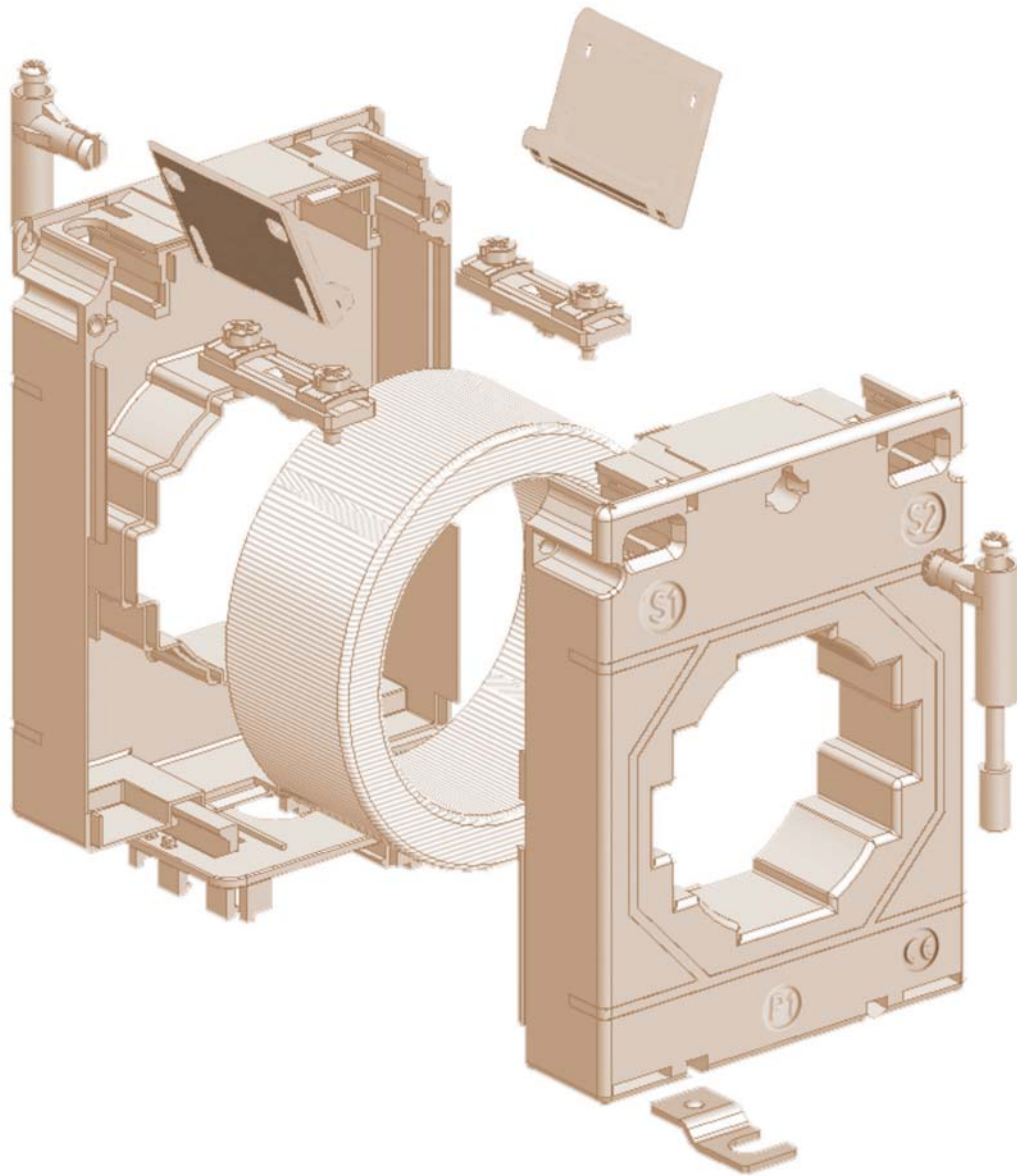

© Ziegler Instruments Order No. ZIS 8.50C Data sheet-EL.R0-930714-41-2014-EN

ZIEGLER CURRENT TRANSFORMER SERIES

Ziegler Instruments, leader in measuring instruments unveils its world class plastic cased Square and Round Current Transformers. Ziegler Current Transformers or Ziegler CT's as they are better known are encased with polycarbonate housing conforming to UL 94V-0. These are available for different ratings, VA burdens & Accuracy classes. The catalog describes the different possible combinations.

GENERAL SPECIFICATION

- | **APPLICABLE STANDARD:** IEC/EN 60044 -1, BS 3938
- | **CASE:** 10% glass filled polycarbonate, flame retardant grades classified UL 94V-0.
- | **CONNECTION:** Two connection on each side. M4 screws with self lifting clamp strap assembly for Ziegler ZiS series and 1 connection on each side M4 screws with self lifting clamp strap for Ziegler ZiR series.
- | **INSULATION CLASS:** E (120°C max)
- | **SYSTEM VOLTAGE:** 720V maximum
- | **TEST VOLTAGE:** 4kV 50 Hz 1 min
- | **OPERATING FREQUENCY:** 50Hz or 60Hz
- | **RATED PRIMARY RATING:** 30A to 4000A
- | **RATED SECONDARY OUTPUT:** 5A standard (1A optional)
- | **RATED BURDEN:** 1, 1.25, 1.5, 2.5, 3.75, 5, 7.5,10, 12.5,15,20, 30, 45, 60 VA
- | **CLASS OF ACCURACY:**
0.2, 0.2S for Laboratory and Power Measurement
0.5, 0.5S for accurate measuring, kWh
1 for General Measurement
3 for Indicating Instruments
- | **AMBIENT TEMPERATURE:** -20°C...+45°C
- | **STORAGE TEMPERATURE:** -50°C...+80°C
- | **THERMAL SHORT CIRCUIT CURRENT (I_{TH}):** 60xI_n
- | **DYNAMIC SHORT CIRCUIT CURRENT (I_{DYN}):** 2.5xI_{th}
- | **INSTRUMENT SECURITY FACTOR:** 2.5, 5, 10

CONNECTION- WIRE CONSUMPTION IN [VA]

Cross section (mm ²)	For secondary current I _{sec} =5A								For secondary current I _{sec} =1A										
	L= distance from CT to measuring point								L= distance from CT to measuring point										
	1m	2m	4m	6m	8m	10m	15m	20m	1m	2m	4m	6m	8m	10m	15m	20m	30m	40m	50m
2x0.5	1.837	3.670	7.350	11.02	---	---	---	---	0.074	0.150	0.300	0.440	0.590	0.740	1.110	1.480	2.220	2.960	3.700
2x0.75	1.235	2.470	4.940	7.410	9.880	---	---	---	0.049	0.100	0.200	0.290	0.390	0.490	0.740	0.980	1.470	1.960	2.450
2x1	0.918	1.840	3.670	5.510	7.340	9.180	---	---	0.037	0.070	0.150	0.220	0.300	0.370	0.560	0.740	1.110	1.480	1.850
2x1.5	0.613	1.230	2.450	3.680	4.940	6.130	9.200	---	0.025	0.050	0.100	0.150	0.200	0.250	0.380	0.500	0.750	1.000	1.250
2x2.5	0.368	0.740	1.470	2.210	2.940	3.680	5.520	7.360	0.015	0.030	0.060	0.090	0.120	0.150	0.230	0.300	0.450	0.600	0.750
2x4	0.233	0.470	0.930	1.400	1.860	2.330	3.500	4.660	0.009	0.020	0.040	0.050	0.070	0.090	0.140	0.180	0.270	0.360	0.450
2x6	0.149	0.300	0.600	0.890	1.190	1.490	2.230	2.980	0.003	0.006	0.012	0.018	0.024	0.030	0.045	0.060	0.090	0.120	0.150

TABLE NO. 1

VA BURDEN GUIDE

- | Moving iron ammeter (frame dimension of 48, 72, 96, 144) 1.0 VA
- | Bimetal instruments (.../5A) 3.0 VA
- | Bimetal and Moving iron instruments (.../5A) 3.5 VA
- | Wattmeter 5.5 VA
- | Power factor meter 4.0 VA
- | Current transducer 0.5 VA
- | Power transducer 0.5 VA
- | kWh-meter 2.5 VA
- | Trivector meter 5.0 VA

FEATURES

- | Comprehensive measurement of class accuracy
- | Cost effective moulded case current transformer
- | Wide range of system current ratings bus bar sizes, case widths and apertures
- | Various mounting options like wall mounting, cable mounting, bus bar mounting, DIN rail mounting
- | Wire sealable terminal covers

INDEX

Primary Current Range (Amp.)	Primary Conduction upto		CT Width	Type	Page
	Busbar	Round Conductor			
SQUARE TYPE CT's					
40...300	-	14 mm	40 mm	ZiS 4.14B	155
50...400	-	21 mm	40 mm	ZiS 4.21B	155
50...300	-	14 mm	31 mm	ZiS 5.14A	156
50...400	10.5 mm x 20.5 mm	14 mm	51 mm	ZiS 5.14D	156
75...600	10.5 mm x 30.5 mm	21 mm	31 mm	ZiS 5.21A	157
50...300	-	21 mm	51 mm	ZiS 5.21D	157
50...400	10.5 mm x 20.5 mm	25 mm	31 mm	ZiS 5.30A	158
50...600	10.5 mm x 30.5 mm	25 mm	51 mm	ZiS 5.30D	158
50...600	20.5 mm X 12.5 mm	20 mm	40 mm	ZiS 6.20B	159
50..400	-	22 mm	40 mm	ZiS 6.22B	159
50...800	31 mm X 11 mm	30 mm	40 mm	ZiS 6.30B	160
100...800	40.5 mm X 11 mm	31 mm	40 mm	ZiS 6.40B	160
30...400	21 mm X 11 mm	20.4 mm	45 mm	ZiS 7.20C	161
30...800	31 mm X 15 mm	26 mm	45 mm	ZiS 7.30C	161
40...1000	41 mm X 12.5 mm	35 mm	45 mm	ZiS 7.40C	162
100...1000	51 mm X 12.5 mm	41 mm	45 mm	ZiS 7.50C	162
50...1000	41 mm X 11 mm	36 mm	45 mm	ZiS 8.40C	163
100...1250	51 mm X 12.5 mm	46 mm	45 mm	ZiS 8.50C	163
100...1600	61 mm X 21 mm	51 mm	45 mm	ZiS 8.60C	164
400...2600	103 mm X 41 mm	—	45 mm	ZiS 10.10VC	164
400...3200	128 mm X 38 mm	—	45 mm	ZiS 10.13VC	164
100...1600	61 mm X 12.5 mm	54 mm	45 mm	ZiS 10.60C	165
200...2000	81 mm X 12.5 mm	65 mm	45 mm	ZiS 10.80C	165
200...2000	81 mm X 31 mm	73 mm	45 mm	ZiS 14.80C	165
200...4000	101 mm X 31 mm	86 mm	45 mm	ZiS 14.10VC	166
200...3000	101 mm X 31 mm	86 mm	45 mm	ZiS 14.10HC	166
600...7500	167 mm x 66 mm	--	50 mm	ZiS 22.16D	167
1000...7500	125 mm x 93 mm	--	50 mm	ZiS 22.12D	167
1A ... 25A	Wound Primary	-	40 mm	ZiS 6.WPB	167
1A ... 50A	Wound Primary	-	45 mm	ZiS 7.WPB	169
100 to 6000A	Protection CT	(Refer Table)	-	ZiP Series	169
ROUND TYPE CT's					170-173
Current Range	Primary Conduction for		CT Width	Type	Page
	Busbar	Round Conductor			
50...150	-	30 mm	40 mm	ZiR 7.30B	
50...200	-	40 mm	50 mm	ZiR 7.30D	176
400...600	-	43 mm	41 mm	ZiR 8.43B	176
400...600	-	58 mm	41 mm	ZiR 10.58B	177
800...1000	-	72 mm	41 mm	ZiR 11.72B	177
1200...3200	-	113 mm	40 mm	ZiR 15.113B	178
CT Routine Test Info	-	-	-	-	178

179

► **ALLOWABLE LOAD CAPACITY OF PAINTED COPPER AND ALUMINUM BARS**

Allowable load capacity of painted copper and aluminum bars Bar section vertical. Bars are separated the thickness of one bar						
Maximum current in A						
Dimensions (mm)	1 bars		2 bars		3 bars	
	Copper	Aluminum	Copper	Aluminum	Copper	Aluminum
12 X 2	150	80	232	140	262	--
15 X 2	180	95	275	170	300	--
15 X 3	282	115	364	210	440	--
20 X 2	230	120	348	270	360	--
20 X 3	290	145	453	350	520	--
20 X 5	319	254	560	446	728	570
20 X 10	497	393	924	730	1320	1060
25 X 3	350	180	540	330	600	--
25 X 5	470	230	760	430	965	--
30 X 3	410	205	625	385	680	--
30 X 5	447	356	760	606	944	739
30 X 10	676	536	1200	956	1670	1340
40 X 3	530	280	800	500	835	--
40 X 5	573	456	952	762	1140	898
40 X 10	850	677	1470	1180	2000	1650
50 X 5	697	556	1140	916	1330	1050
50 X 10	1020	815	1720	1400	2320	1940
60 X 5	826	655	1330	1070	1510	1190
60 X 10	1180	951	1960	1610	2610	2200
80 X 5	1070	851	1680	1360	1830	1460
80 X 10	1500	1220	2410	2000	3170	2660
100 X 5	1300	1050	2010	1650	2150	1730
100 X 10	1810	1480	2850	2390	3720	3110
120 X 10	2570	1350	3780	2400	4600	3250
160 X 10	3290	1750	4750	3000	5800	4150
200 X 10	4000	2150	5700	3650	6950	4950
200 x 15		2550		4200	-	5600

TABLE NO. 1

► **LIMITS OF CURRENT ERROR AND PHASE DISPLACEMENTS (CLASSES FROM 0.1 TO 1)**

Limits of current error and phase displacements for measuring current transformers (Classes from 0.1 to 1)												
Accuracy class	+/- percentage current (ratio) error at percentage of rated current shown below				+/- phase displacements at percentage of rated current shown below							
					Minutes				Centiradians			
	5	20	100	120	5	20	100	120	5	20	100	120
0.1	0.4	0.2	0.1	0.1	15	8	5	5	0.45	0.24	0.15	0.15
0.2	0.75	0.35	0.2	0.2	30	15	10	10	0.9	0.45	0.3	0.3
0.5	1.5	0.75	0.5	0.5	90	45	30	30	2.7	1.35	0.9	0.9
1	3	1.5	1	1	180	90	60	60	5.4	2.7	1.8	1.8

TABLE NO. 2

► **LIMITS OF CURRENT ERROR AND PHASE DISPLACEMENTS (FOR SPECIAL APPLICATION)**

Limits of current error and phase displacements for measuring current transformers (For special application)															
Accuracy class	+/- percentage current (ratio) error at percentage of rated current shown below					+/- phase displacements at percentage of rated current shown below									
						Minutes									
	1	5	20	100	120	1	5	20	100	120	1	5	20	100	120
0.2S	0.75	0.35	0.2	0.2	0.2	30	15	10	10	10	0.9	0.45	0.3	0.3	0.3
0.5S	1.5	0.75	0.5	0.5	0.5	90	45	30	30	30	2.7	1.35	0.9	0.9	0.9

TABLE NO. 3

► **LIMITS OF CURRENT ERROR (CLASSES 3 AND 5)**

Class	+/- percentage current (ratio) error at percentage of rated current shown below	
	50	120
3	3	3
5	5	5

TABLE NO. 4

► **CURRENT ERROR (RATIO ERROR):**

The error with a transformer introduces into the measurement of a current and which arises from the fact that actual transformation ratio is not equal to the rated transformer ratio.

THE CURRENT ERROR EXPRESSED IN PERCENTAGE IS GIVEN BY THE FORMULA:

$$\text{Current error, percent} = (K_a \cdot I_p - I_s) \times 100 / I_p$$

Where K_a = rated transformation ratio

I_p = actual primary current

I_s = actual secondary current when I_p is flowing under the conditions of measurement

PHASE DISPLACEMENT:

The difference in phase between the primary and secondary current vectors, the direction of the vectors being so chosen that the angle is zero for the perfect transformer. The phase displacement is said to be positive when the secondary current vector leads the primary current vector. It is usually expressed in minutes.

ACCURACY CLASS:

A designation assigned to a current transformer the errors of which remain within specified limit under prescribed conditions of use.

RATED BURDEN:

The impedance of the secondary circuit on which the accuracy requirements are based. It is usually expressed as apparent power (in VA), at the rated secondary current and at a specified power factor.

HIGHEST SYSTEM VOLTAGE:

The highest RMS line to line voltage which can be sustained under normal operating conditions at any time and at any point on the system. It excludes temporary voltage variations due to fault condition and the sudden disconnection of large loads.

RATED INSULATION LEVEL:

That combination of voltage values (power frequency and lightning impulse, or where applicable, lightning and switching impulse) which characterizes the insulation of a transformer with regard to its capability to withstand by dielectric stresses. For low voltage transformer the test voltage 4kV, at power-frequency, applied during 1 minute.

RATED DYNAMIC CURRENT (I_{DYN}):

The peak value of the primary current which a current transformer will withstand, without being damaged electrically or mechanically by the resulting electromagnetic forces, the secondary winding being short-circuited.

RATED CONTINUOUS THERMAL CURRENT:

The value of current which can be permitted to flow continuously in the primary winding, the secondary windings being connected to the rated burdens, without the temperature rise exceeding the specified values.

INSTRUMENT SECURITY FACTOR (ISF):

The ratio of rated instrument limit primary current to the rated primary current. The times that the primary current must be higher than the rated value, for the composite error of a measuring current transformer to be equal to or greater than 10%, the secondary burden being equal to the rated burden. The lower this number is, the more protected the connected instrument are against.

ZIS 8.50C

ZIEGLER ZIS 8 SERIES CURRENT TRANSFORMER

ZiS 8.50C

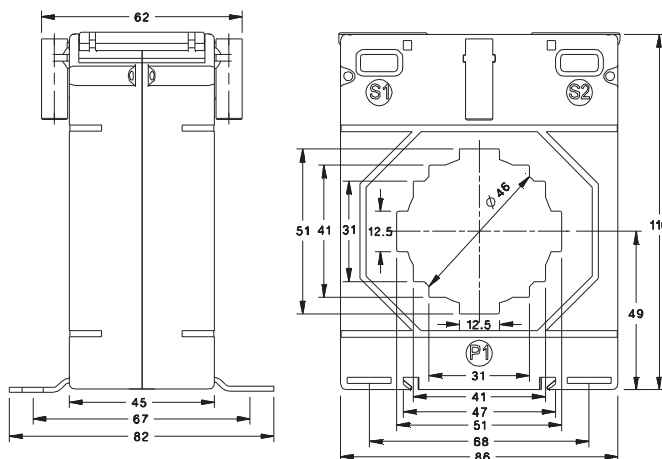

DIMENSIONAL DRAWING

ZIS 8 SERIES CURRENT TRANSFORMER POSSIBLE COMBINATIONS

All dimensions are in mm

Rated Primary Current	ZiS 8.50C				
	Accuracy Class				
	0.2S	0.2	0.5	1	3
100A	-	-	-	1.5VA	2.5VA
120A	-	-	1.5VA	2.5VA	3.75VA
125A	-	-	1.5VA	2.5VA	3.75VA
150A	-	-	2.5VA	5.0VA	7.5VA
200A	-	-	5.0VA	7.5VA	10VA
250A	-	-	7.5VA	10VA	12.5VA
300A	1.5VA	1.5VA	7.5VA	10VA	12.5VA
400A	2.5VA	2.5VA	15VA	15VA	15VA
500A	2.5VA	5.0VA	15VA	20VA	20VA
600A	5.0VA	7.5VA	15VA	20VA	-
750A	7.5VA	10VA	15VA	20VA	-
800A	10VA	12.5VA	20VA	30VA	-
1000A	12.5VA	20VA	30VA	30VA	-
1200A	12.5VA	20VA	30VA	30VA	-
1250A	12.5VA	20VA	30VA	30VA	-

ORDER EXAMPLE : ZiS 8.50C 1200A/5A, CL.0.2, 20VA

NOTE : On request orders for types different from table are accepted.
1A Secondary available on request
On request order for clip DIN EN 50022 rail are accepted.

SYS VTG.: 720Vmax
TEST VTG.: 4kV 50 Hz 1min

ZIEGLER INSTRUMENTS

Schnepfenreuther Weg 6, D-90425 Nürnberg, Germany.

TEL. | (+49)(911) 38 492 45 E-MAIL | info@ziegler-instruments.com
FAX. | (+49)(911) 32 26 212 WEBSITE | www.ziegler-instruments.com

made
in
Germany

Ziegler
Redefine Innovative Metering

► **ROUTINE TEST:**

Tests carried out on each current transformer to check requirements likely to vary during production.

The following tests apply to each individual transformer:

- A. Verification of terminal markings
- B. Power–frequency withstand test primary winding.
- C. Partial discharge measurement.
- D. Power–frequency withstand test on secondary windings.
- E. Power–frequency withstand test, between sections.
- F. Inter–turn over voltage test
- G. Determination of errors.

The order of the tests is not standardized, but determination of

► **SPECIAL TESTS / OPTIONAL TESTS:**

Test which may be in the nature of type tests or routine tests, and are carried out only by agreement between manufacturer

► **SHORT TIME CURRENT TEST:**

For the thermal short time current (I_{th}) test the transformer shall be at a temperature 10°C to 40°C. The test shall be made with the secondary winding short circuited and at the current “I” for a time “t”, so that (I^2t) is not less than (I_{th}^2) and provided t has a value between 0.5s and 5s.

The dynamic test shall be made with the secondary winding (s) short–circuited and with a primary current the peak value of which is not less than the rated dynamic current (I_{dyn}) for at least one peak.

The dynamic test may be combined with the thermal test above, provided the first major peak current of that test is not less than the rated dynamic current (I_{dyn}).

The transformer shall be deemed to have passed these tests if, after cooling to ambient temperature (between 10°C and 40°C), it satisfies the following requirements:

- A. It is not visibly damaged;
- B. Its errors after demagnetization do not differ from those recorded before the tests by more than half the limits of error appropriate to its accuracy class
- C. It withstands the dielectric tests specified in 8.2, 8.3 and 8.4 but with the test voltage or currents reduced to 90% of those given.
- D. On examination, the insulation next to the surface of the conductor does not show significant deterioration (e.g. Carbonization).

► **TEMPERATURE-RISE TEST:**

A test shall be made to prove compliance with the requirement of 4.6. for the purpose of this test, current transformers shall be deemed to have attained steady temperature when the rate of temperature rise does not exceed 1 K per hour.

The test–site ambient temperature shall be between 10°C and 30°C. For the test the transformer shall be mounted in a manner representative of the mounting in service.

The temperature rise of winding shall, when practicable, be measured by the increase in resistance method, but for winding of very low resistance, thermocouples may be employed.

The temperature rise of parts other than windings may be measured by thermometer or thermocouples.

► **VERIFICATION OF TERMINAL MARKINGS:**

It shall be verified that the terminal markings are correct.

► **POWER-FREQUENCY TEST:**

The power frequency withstand test shall be performed in accordance with IEC 60060–1.

The test voltage shall have the appropriate value given in table 3 or 5 (in IEC 60044–1 standard) depending on the highest voltage for equipment. The duration shall be 60sec.

The test voltage shall be applied between the short–circuited primary winding and earth. The short–circuited secondary winding (s), the frame, case (if any) and core (if there is a special earth terminal) shall be connected to earth.

► **INTER-TURN OVER VOLTAGE TEST:**

The inter–turn over voltage test shall be performed in accordance with one of the following procedures.

Procedure : with the primary winding open–circuited, the prescribed test voltage (at same suitable frequency) shall be applied for 60sec to the terminals of each secondary winding, providing that the r m s value of the secondary current does not exceed the rated secondary current (or rated extended current).

The value of the test frequency shall not be greater than 400 Hz. At this frequency if the voltage value achieved at the rated secondary current (or rated extended current) is lower than 4.5 kV peak the obtained voltage is to be regarded as the best voltage. When the frequency exceeds twice the rated frequency, the duration of the test may be reduced from 60 s.

(**Note:** The tests which are applicable to ring type/ window type, low tension, [LT] C.T. are given here. For remaining test procedure,

► **TYPE TEST:**

Tests carried out to prove the general qualities and design of a given type of current transformer in accordance with the requirements of the applicable standards.

Tests may be carried out on a prototype which may incorporate special arrangements for the measurements required by applicable standard.

The following tests are type test:

- A. Short time current test
- B. Temperature rise test
- C. Lightning impulse test
- D. Switching impulse test
- E. Wet test for outdoor type transformer
- F. Determination of errors
- G. Radio Interference Voltage measurement (RIV) (As specified in IEC 60044–1)

All the dielectric type test should be carried out on the same